

Installation Manual

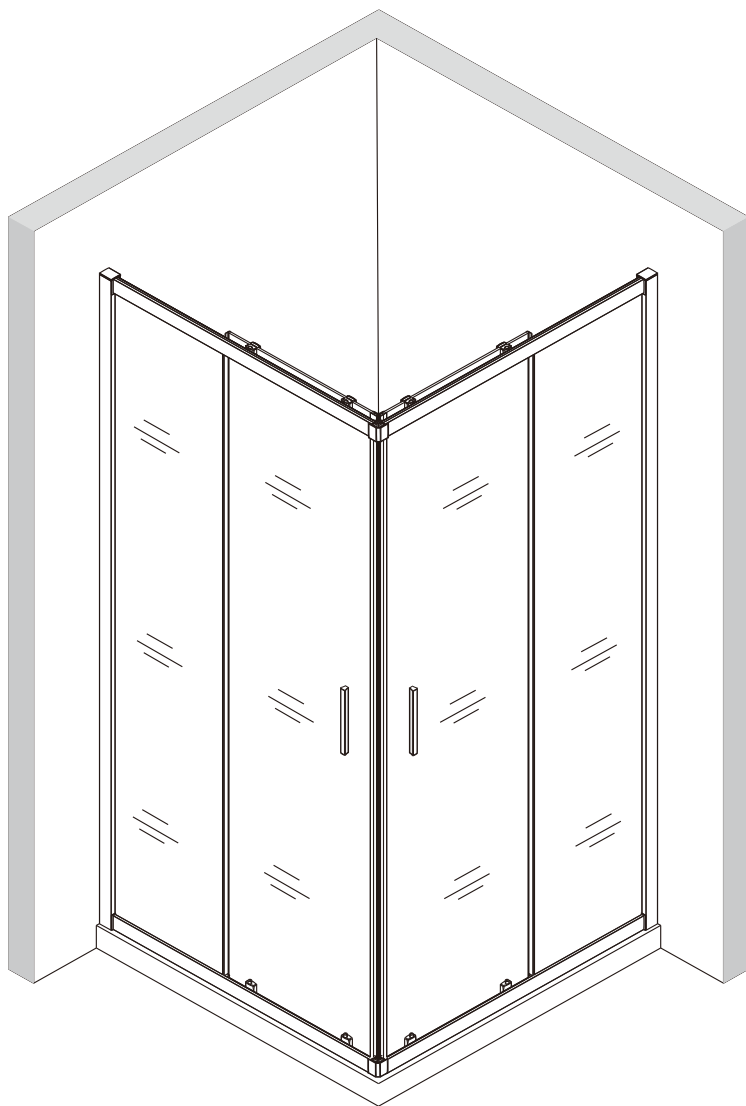

CAUTIONS

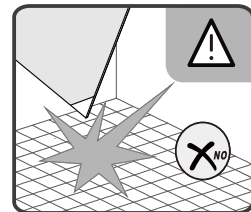
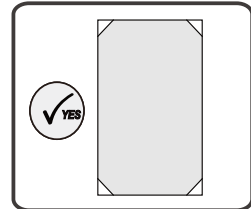
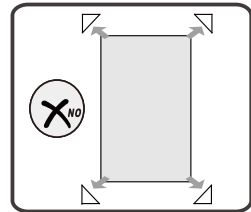
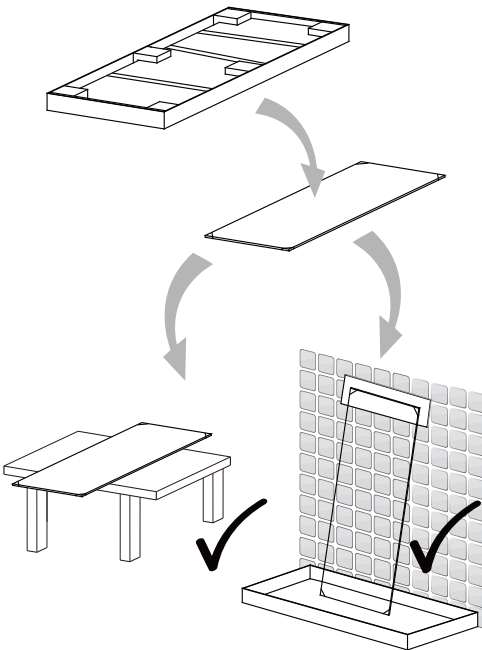
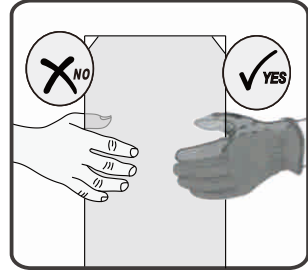
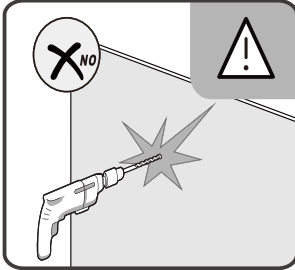

TOOLS REQUIRED

	English	Tape measure
	Deutsch	Maßband
	Français	Mètre ruban
	Italiano	Metro a nastro
	Español	Cinta métrica
Polski	Taśmado mierzenia	

	English	Spirit level
	Deutsch	Wasserwaage
	Français	Niveau à bulle
	Italiano	Livella a bolla
	Español	Nivelador
Polski	Poziomica	

	English	Drill
	Deutsch	Bohrmaschine
	Français	Perceuse
	Italiano	Trapano elettronico
	Español	Taladro
Polski	Wiertarka	

	English	Rubber hammer
	Deutsch	Bummihammer
	Français	Marteau en caoutchouc
	Italiano	Martello di gomma
	Español	Mazo de goma
Polski	Gumowy młotek	

	English	Silicone gun
	Deutsch	Silikonpistole
	Français	Pistolet à silicone
	Italiano	Pistola di silicone
	Español	Pistola de silicona y silicona
Polski	Silikon I pistolet	









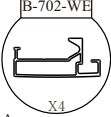

	English	Drill bit
	Deutsch	Bohrer
	Français	Foret
	Italiano	Punta da trapano
	Español	Broca
Polski	Wiertła	

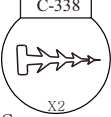
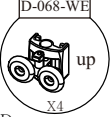
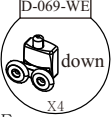
	English	Flat head & cross head screwdriver
	Deutsch	Schraubenzieher
	Français	Tournevis à tête plate & à lame
	Italiano	Cacciavite a testata piatta e croce
	Español	Destornillador plano y de cruz
Polski	Plaski i krzyżowy śrubokręt	

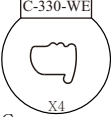
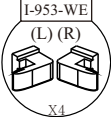
	English	Pencil
	Deutsch	Bleistift
	Français	Crayon
	Italiano	Matita
	Español	Lápiz
Polski	Ołówek	

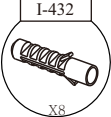
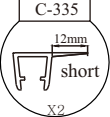
	English	Allen key
	Deutsch	Inbusschlüssel
	Français	Clé Allen
	Italiano	chiave a testa esagonale
	Español	Llave L
Polski	klucz sześciokątny	

PACKING LIST

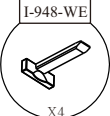
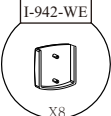
 B-702-WE X4 A	 B-823-WE X2 B	 C-338 X2 C	 D-068-WE up X4 D	 D-069-WE down X4 E	 I-1084-WE (L) (R) X2 F	 C-330-WE X4 G
 I-953-WE (L) (R) X4 H	 ST4*40 X8 I	 I-432 X8 J	 C-335 12mm short X2 K	 C-335 12mm long X2 L	 E-171-WE X2 M	 C-349 X2 N
 I-958-WE X2 O	 I-948-WE X4 P	 I-942-WE X8 Q				

PRODUCT SCHEMATIC DIAGRAM

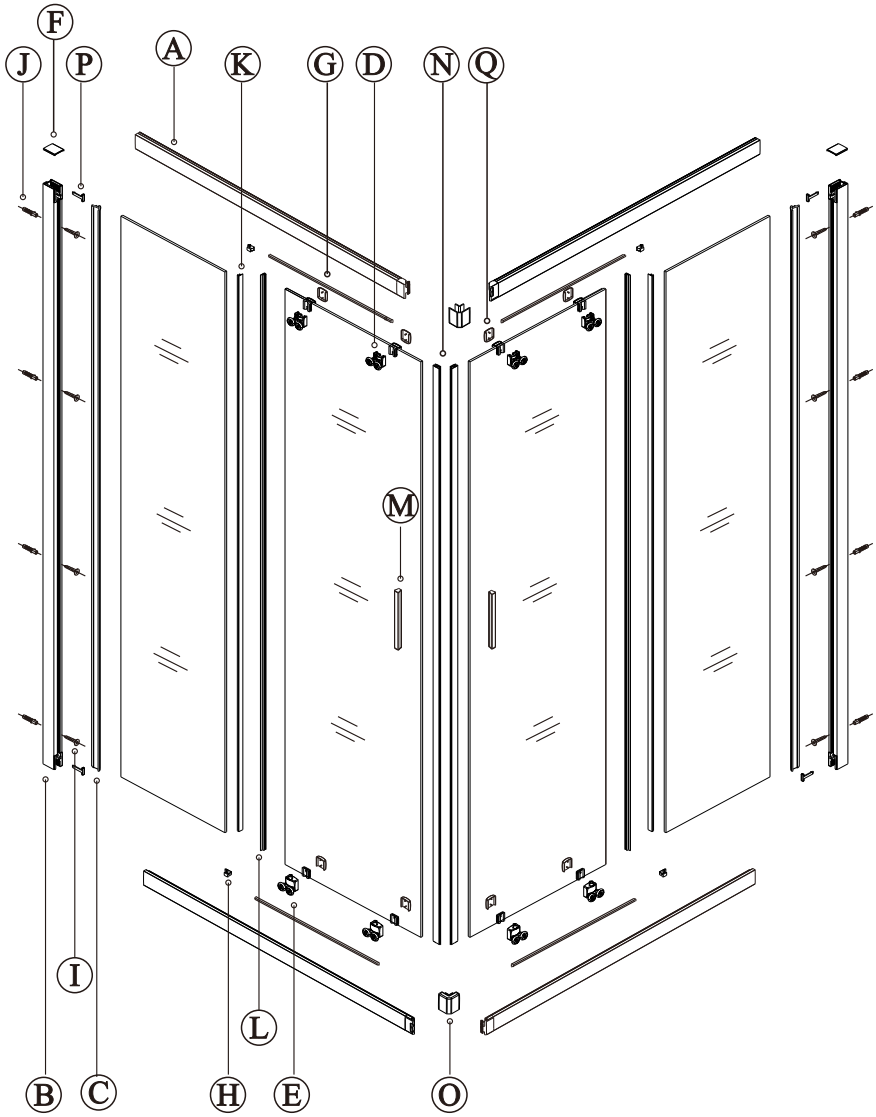

(1)

1

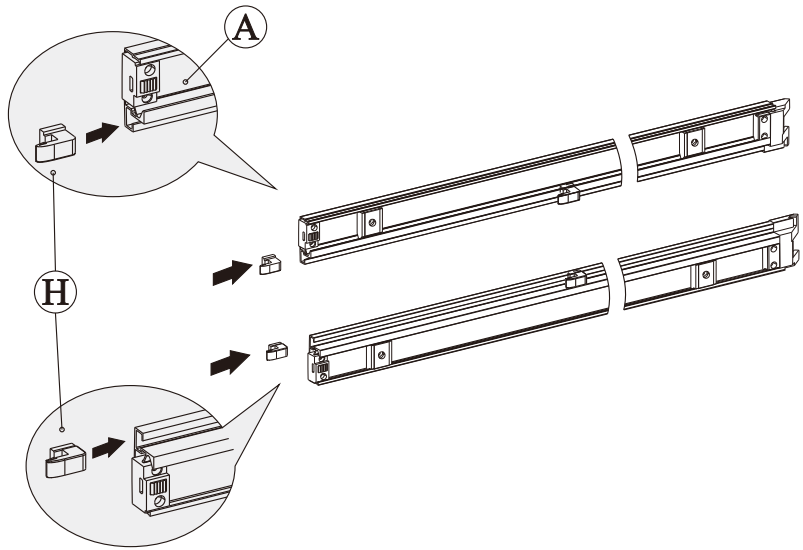

2

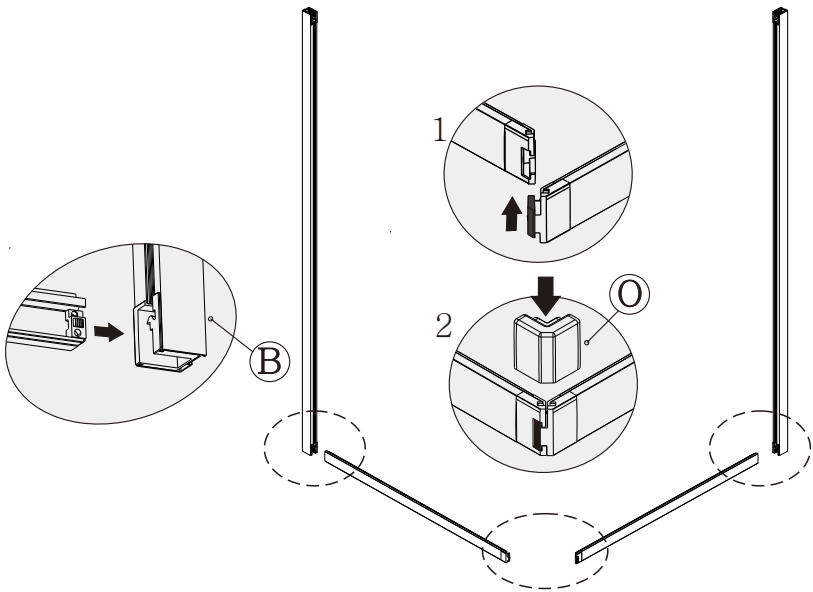

(2)

3

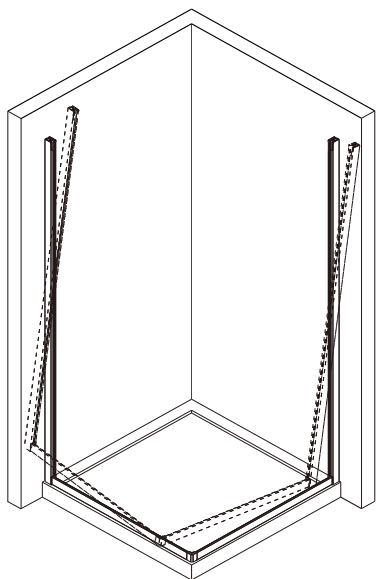

4

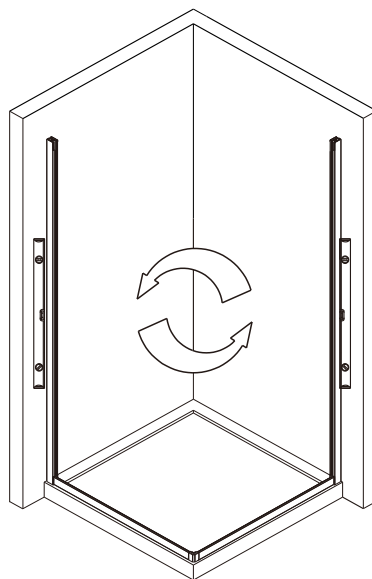

5

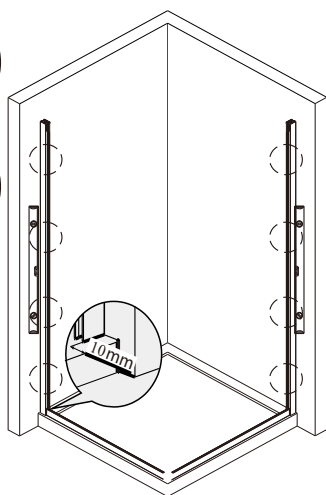
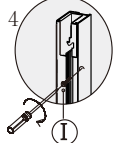
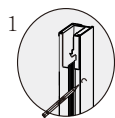

English	10 mm gap from the edge of wall profile to the outside edge of the tray, which make sure enough room for fitting the water retaining cover.
Deutsch	Befestigungsklammer soll ca. 10 mm vor der Duschtasse grenze befestigt werden.
Français	Il faut laisser un écart de 10mm entre le bord du receveur et du profilé mural afin de garantir une espace pour l'installation du rail d'étanchéité.
Italiano	Fra il bordo del piatto doccia e il profilo a muro deve rimanere uno spazio di 10 mm per evitare la fuoriuscita di acqua.
Español	Instalar el perfil de pared por lo menos 10mm del borde del plato de ducha, así dar espacio para instalar el accesorio de prevención prevención de salida de agua.
Polski	Odstęp między profilem ściennym a zewnętrzną krawędzią brodzika powinien wynosić ok. 10mm, co zapewni wystarczające miejsce na dolną pokrywkę zatrzymującą wodę całkowicie znajdującą się na brodziku i zapobiegającą wyciekaniu wody.
Nederlands	Plaats de muurprofielen op minimaal 10 mm afstand van de douchebak rand, zodat er voldoende ruimte is voor het plaatsen van het waterkerend deksel.

(3)

6

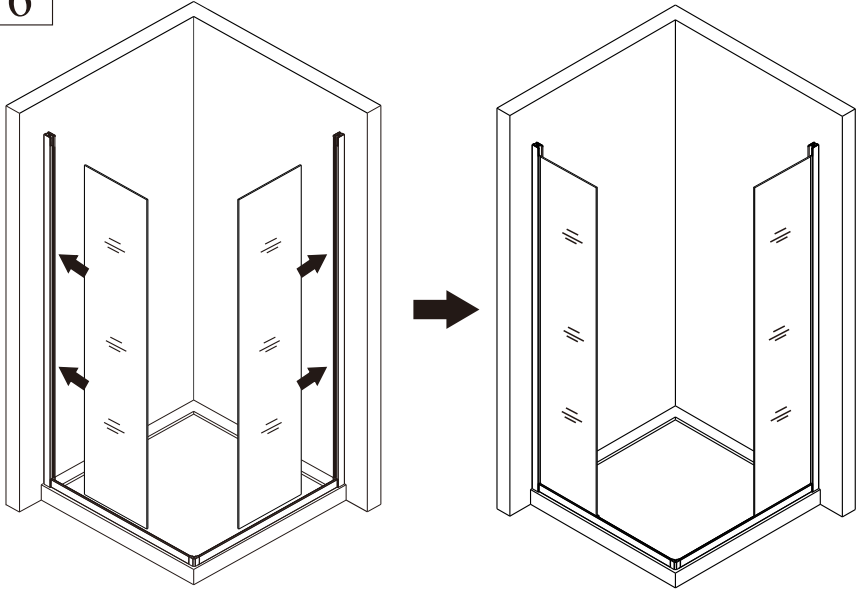

7

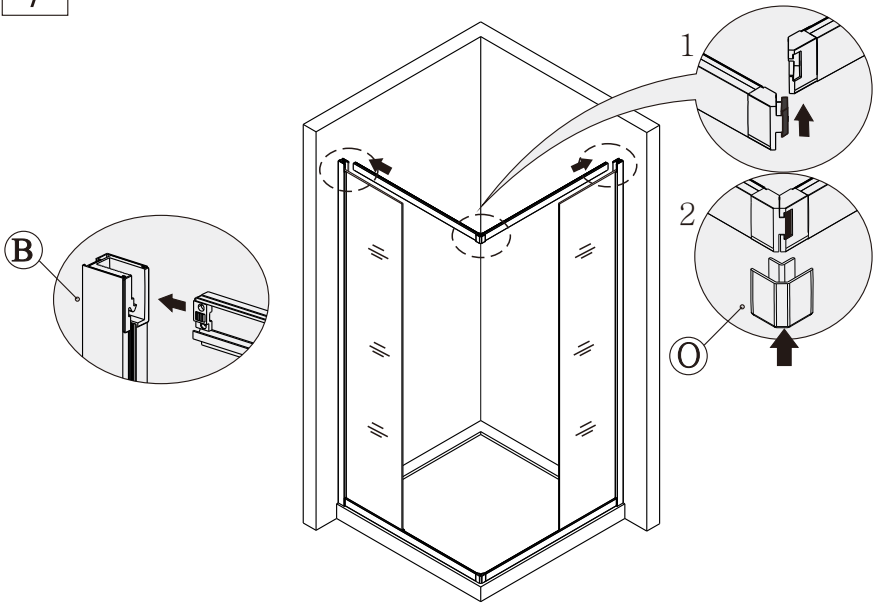

(4)

8

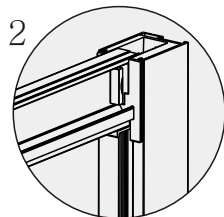
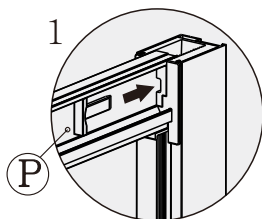
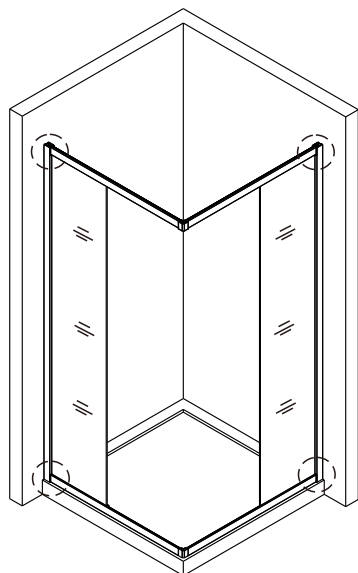

9

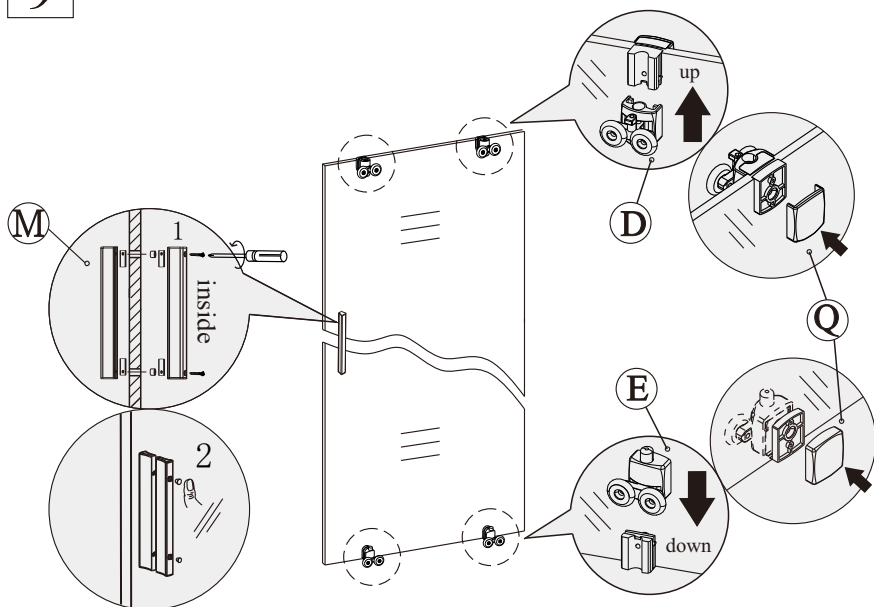

(5)

10

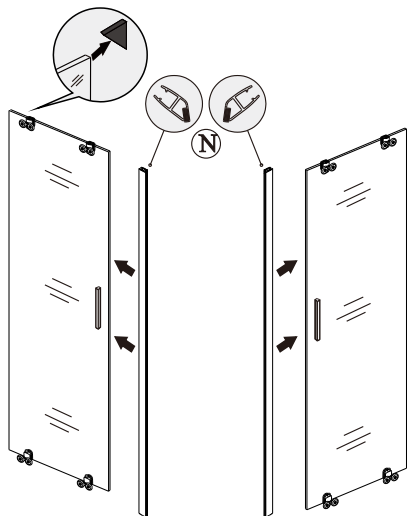

English	Please make sure that the corner protectors are left until after the item has been installed this protects the glass from any breakage.
Deutsch	Bitte gewährleisten Sie sicher, dass die Eckenschützer links stehen bleiben, bis der Gegenstand montiert wurde. Auf jeden Fall schützt Dies das Glas besser vor dem Bruch.
Français	Avant de retirer la protection d'angle pour poser d'autres accessoires, si possible, il faut installer bien la vitre.
Italiano	In situazioni che non influiscono sull'installazione, le protezioni per gli angoli del vetro vanno rimosse prima dell'aggiunta di altre componenti.
Español	Matener puestas las protecciones esquineras del cristal, quaitar al momento de montar el cristal e instalar los otros accesorios.
Polski	Podczas montażu szklona narożników szkła musi pozostać. Oslona nie ma wpływu na motaż. Najpierw zamontuj szkło, anastępnie zdejmij osłonę narożników szkła I dokonaj montażu pozostałych elementów.
Nederlands	Zorg ervoor dat u de glazen phoekbeschermers verwijderd nadat u alle accessoires hebt geïnstalleerd.

11

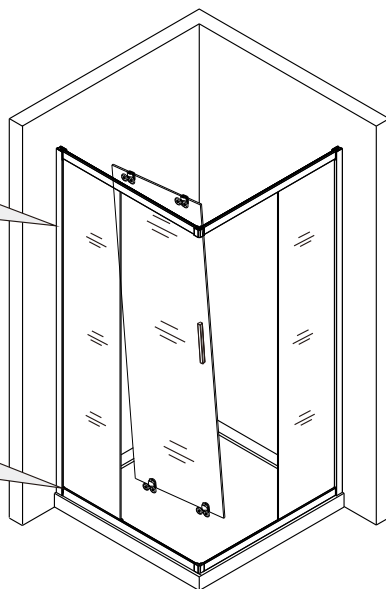
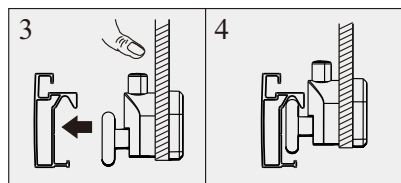
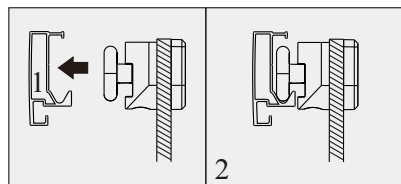

(6)

12

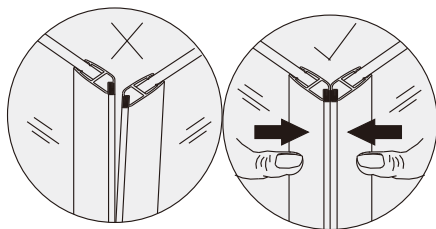
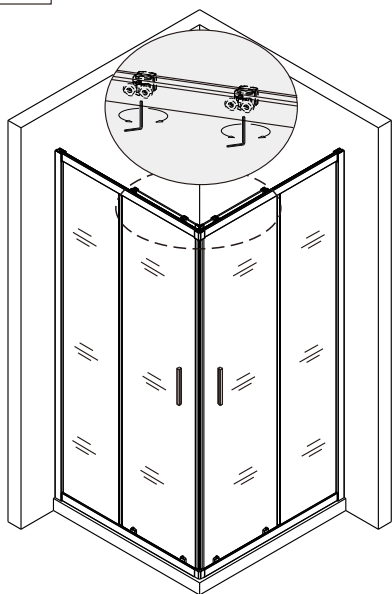

13

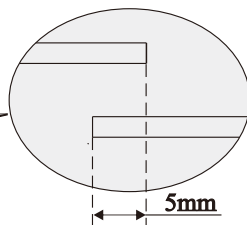
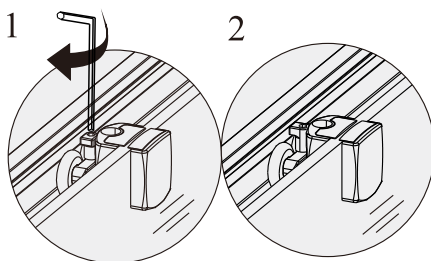
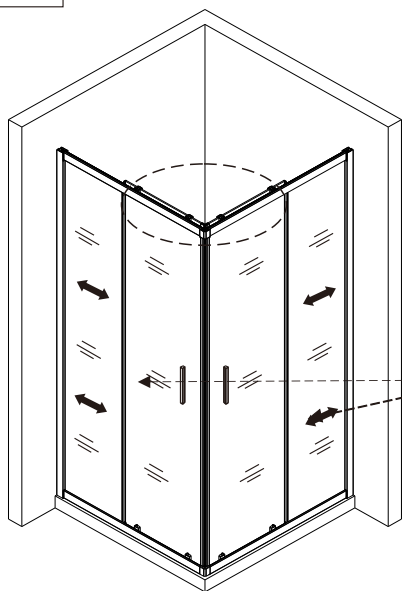

(7)

14

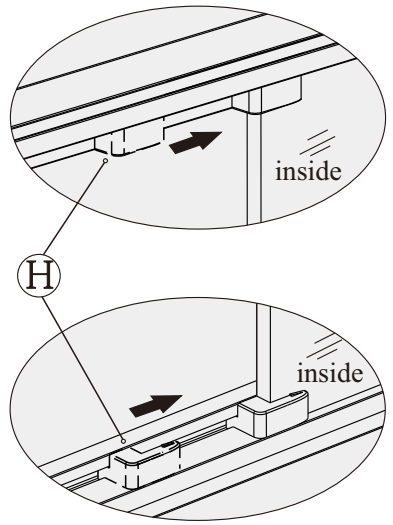
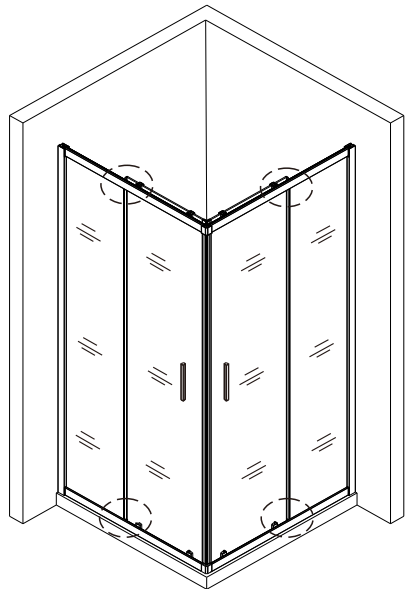

15

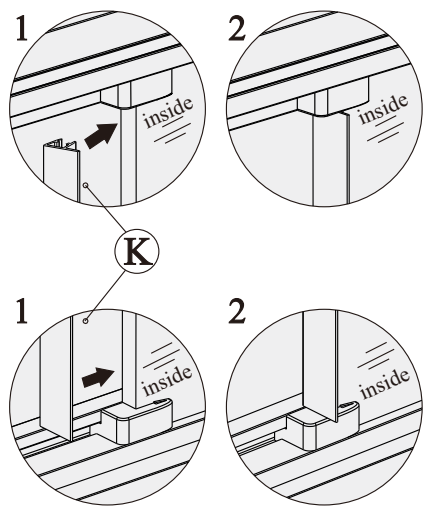
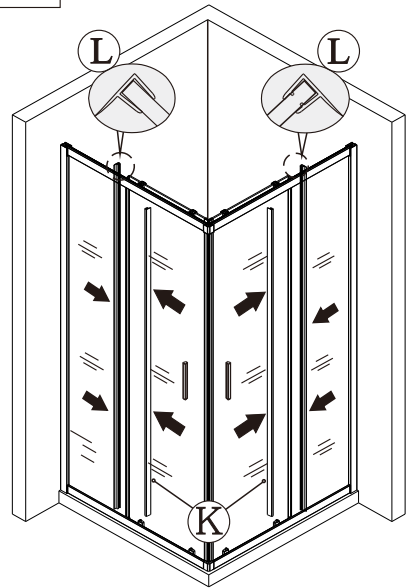

(8)

16

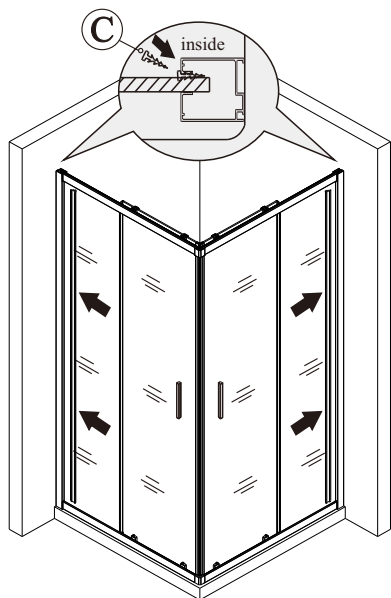

17

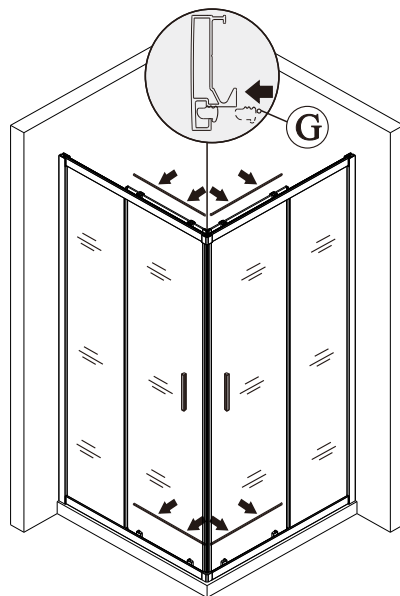

18

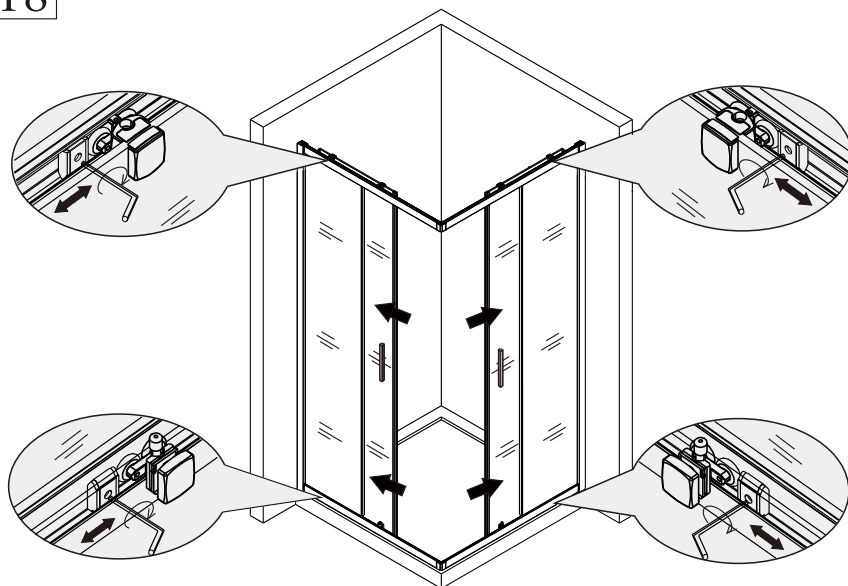

(9)

19

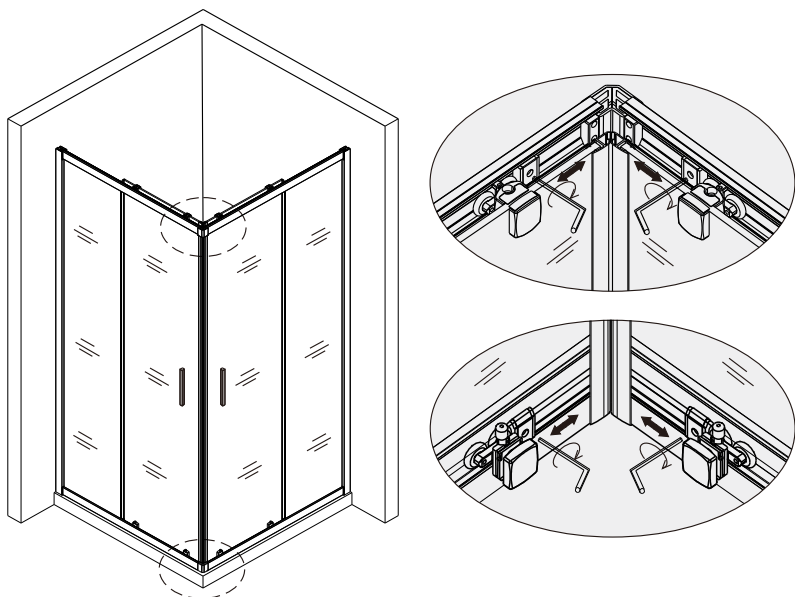

20

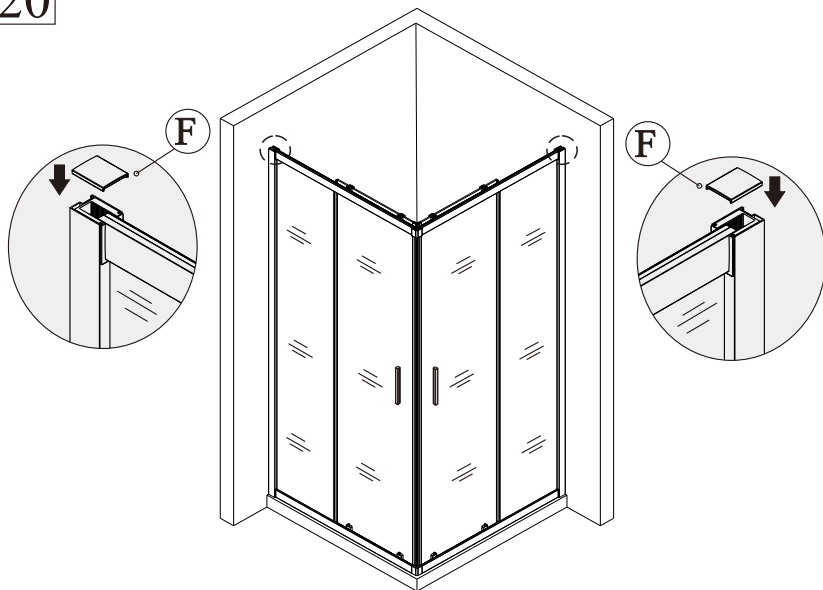

(10)

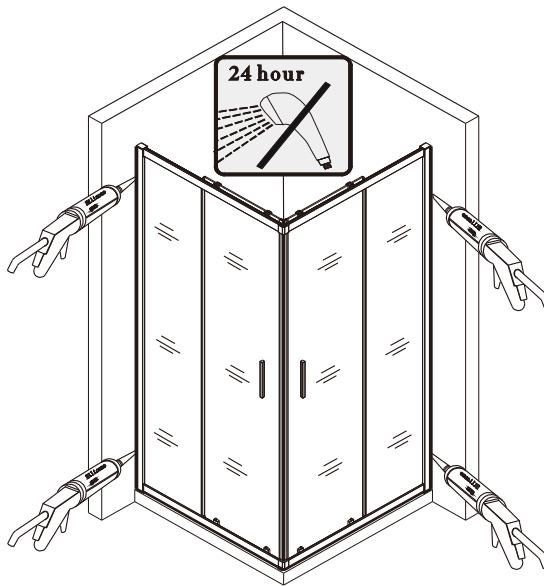

English	Apply some silicone on the outside edge of the shower enclosure (between the wall profiles and wall and between the frame and the tray) to enhance waterproof . After installation , it needs 24 hours for silicone to dry before being put into use .
Deutsch	Bitte tragen Sie Sanitärsilikon von außen zwischen Wand und Wandprofil und zwischen den Profilen auf der Badewanne und der Badewanne auf . Nach dem Auftragen muss das Silikon 24 Stunden trocken , bevor Sie Ihr Produkt das erste Mal nutzen können .
Français	Mettez la silicone à l'extérieur de la porte de douche (entre le profilé mural et le mur et entre le cadre/la baguette et le receveur) . Pas de douche dans 24h après le montage .
Italiano	Applicare del silicone sull'estremità esterna della chiusura del box doccia (tra i profili a muro e muro , e tra i profili ad piatto doccia) per migliorare l'impermeabilizzazione . Dopo l'installazione , sono necessarie 24h per cheil silicone si secchi prima di essere utilizzato .
Español	Aplicar silicon en el exterior del cuarto de ducha entre los perfiles y la pared ; y entre el marco y el plato de ducha , para mejorar la impermeabilidad . Esperar 24hr después de aplicar silicon para usar .
Polski	Należy uszczelnic silikonem profil ścienny do ściany oraz przestrzeń między profilem dolnym a podłożem lub brodzikiem . Podczas montażu brodzika przy ścianie należy również nanieść silikon . Na pełne wyschnięcie silikonu należy czekać 24 godziny .
Nederlands	Kit de douche deur aan de buitenzijde af langs de muren en de douche . Gebruik de doucheruimte pas na 24 uur . Laat de kit volledig uitharden alvorens de douche te gebruiken .

Cleaning & Maintenance

Clean the sundries regularly to prevent the drain from being jammed. Usually, clean the shower enclosure by mop with mild detergent.

Don't clean the shower enclosure with irritant detergent, such as alcohol, gasoline or other chemical cleaner.

Should there be any dirty stains on the shower enclosure, you may clean it by calico with toothpaste, but you need to clean it with water afterwards.

After the installation is completed, if you find there is much noise when the glass door moves, you may add small quantity of lubricant onto the roller wheel, slipping hook and the track.

Nettoyage & Entretien

Enlevez les déchets régulièrement afin d'éviter le blocage de la fuite.

En général, vous pouvez nettoyer la paroi de douche avec une serpillière et des détergents doux.

Veuillez ne pas nettoyer la paroi de douche avec des détergents forts comme l'alcool, l'essence ou autres nettoyeurs chimiques.

S'il y a des taches sur la paroi, vous pouvez utiliser un calicot avec du dentifrice pour la nettoyer, cependant, vous devrez la rincer avec de l'eau après.

Lorsque vous finissez l'installation et s'il y a du bruit quand vous pivotez la porte, vous pouvez appliquer un peu de lubrifiant sur les rouleaux, les charnières et la glissière.

Pulizia e Manutenzione

Pulire il prodotto con uno straccio e sapone delicato, non utilizzare detersivi o saponi aggressivi chimici.

Dopo l'installazione se si sentono rumori all'apertura della porta o si fa fatica ad aprirla si consiglia di usare del lubrificante sulle cerniere per favorire lo scivolamento.

Limpieza y mantenimiento

Limpiar el desagüe regularmente para evitar que el drenaje se atasque.

Limpiar la cabina de ducha con trapo y detergente suave.

No limpiar la cabina de ducha con productos agresivos, como alcohol, gasolina u otro limpiador químico.

Si quedan manchas en la cabina de ducha puede limpiar usando pasta dental y luego agua.

Después que hay terminado la instalación, si nota algún sonido al mover las puertas, puede colocar un poco de aceite lubricante en los rodamientos y/o carril de guía.

CZYSZCZENIE I KONSERWACJA

Do prawidłowego czyszczenia należy używać łagodnych preparatów oraz miękkich ściereczek. Nie wolno czyścić drażniącymi detergentami takimi jak: alkohol, benzyna czy innymi środkami.

Plamy można usuwać za pomocą pasty do zębów nałożoną na ściereczkę (Po jego użyciu należy spłukać wodą).

Jeśli po instalacji kabiny drzwi skrzypią przy otwieraniu i zamykaniu, należy na elementy ruchome takie jak: rorki, uchwyty czy prowadnice nałożyć niewielką ilość środka smarującego.

W celu zapobieżenie zatkaniu się odpływu zalecane jest usuwanie wszelkich zanieczyszczeń regularnie.

Reiniging & Onderhouden

De douchedeur kunt u het best regelmatig met een vochtige doek en schoon water reinigen. Hardnekkige aanslag

kan met een allesreiniger worden schoongemaakt. Eventuele hardnekkige kalkaanslag wordt het best verwijderd met een schoonmaakazijn. Gebruik geen alcohol, benzine of andere sterke chemicaliën om het glas schoon te maken.

Scharnieren, geleiders, geleidingsrail en overige bewegende delen van de douche dienen na de reiniging gecontroleerd te worden of deze nog voldoende vet zijn, dan wel voorzien worden van vet. Gebruik uitsluitend een zuurvrij vet. Aanbevolen wordt een vetop siliconenbasis en vaseline voor huishoudelijk gebruik.